



XWA series

5

XBA series

25

XFA series

49

OPTION

69

OVERVIEW

XWA Series is consisting with basic functions required to control the speed, is a brushless DC motor of small · high power and the unit of panel type driver and lines up 10W~90W for power. Dedicated gearhead had combined with motor and is combination type to susceptible to install.



FEATURE

■ SMALL · HIGH POWER

This product is 90mm(3.54 in) of installation dimension, 57mm(2.24 in) of overall length, operates 90W High Power and attributes to the space saving of equipment.

■ STABILITY FOR EXCELLENT SPEED

Implement excellent speed stability with less speed variation, Speed is not almost change by load such as inverter. Rate for speed variation : below large load $\pm 1\%$, below large voltage, below large $\pm 1\%$

■ On-variable control functions

Speed setting of multistage, instant stop as well as slow start, slow down function that shows great power in a sensitive transportation, can be performed and respond to variable usage methods.

In addition, following features exist.

- Response for high impact gearhead.
- Capable of respond for extending to maximum 10.5m(413.39 in) between motor and driver (Using option cable)
- Speed can be set by external speed adjuster with internal adjuster is not used. (Using the external speed adjuste)

CONTROL UNIT + MOTOR + GEAR HEAD

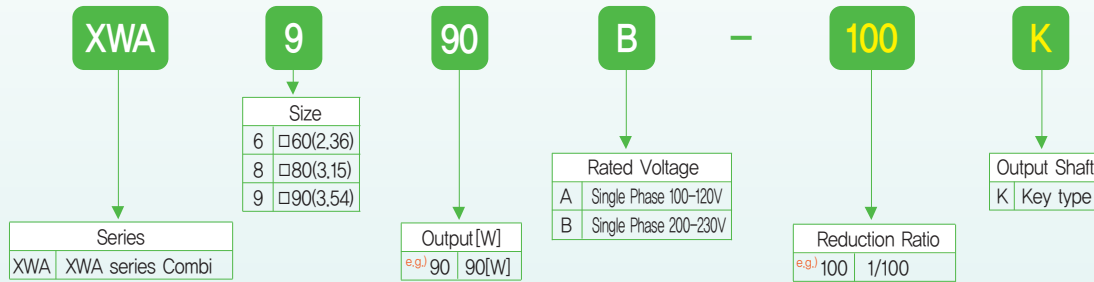

MOTOR + CONTROL UNIT

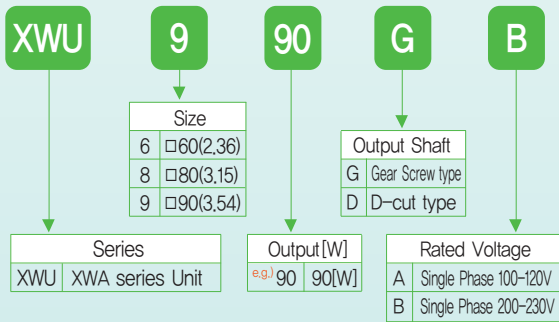

MOTOR

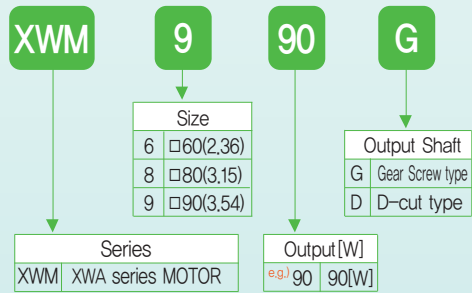

GEAR HEAD

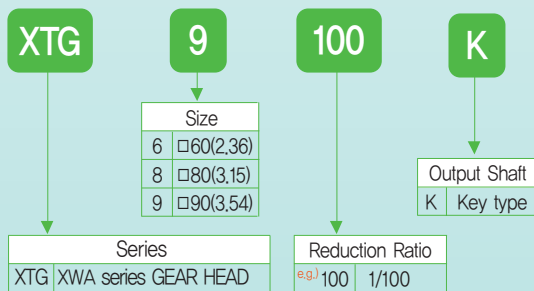

CONTROL UNIT

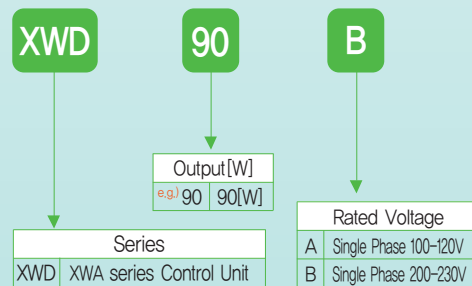

SPECIFICATIONS

Title	Combi type	XWA610A-□	XWA610B-□	XWA825A-□	XWA825B-□	XWA940A-□	XWA940B-□	XWA990A-□	XWA990B-□	
	Gear type	XWM610G		XWM825G		XWM940G		XWM990G		
	D-Cut type	XWM610D		XWM825D		XWM940D		XWM990D		
Rated Output (continuous)	W	10		25		40		90		
Power Input	Voltage	V	Single Phase 100~120	Single Phase 200~230	Single Phase 100~120	Single Phase 200~230	Single Phase 100~120	Single Phase 200~230	Single Phase 100~120	Single Phase 200~230
	Frequency	Hz	50/60		50/60		50/60		50/60	
	Rated Input Current	A	0.6	0.35	0.9	0.56	1.0	0.64	2.0	1.2
	Maximum Input Current	A	0.8	0.5	1.2	0.8	1.3	0.9	2.6	1.6
Rated Torque	N·m(kgf·cm)(lb·in)	0.05(0.5) (0.43)		0.125(1.25) (1.08)		0.20(2.0) (1.73)		0.45(4.5) (3.9)		
Starting Torque	N·m(kgf·cm)(lb·in)	0.06(0.6) (0.52)		0.15(1.5) (1.3)		0.24(2.4) (2.08)		0.54(5.4) (4.68)		
Permissible Load Inertia	J kg·m ² (oz·in ²)	0.5x10 ⁻⁴ (2.7)		1.8x10 ⁻⁴ (9.8)		3.3x10 ⁻⁴ (18.1)		5.8x10 ⁻⁴ (31.7)		
Rated Speed	r/min	2,000								
Speed Control Range	r/min	100 to 2,000 (Speed Ratio 1:20)								
Speed Regulation	Load	Less than ±1% (0 ~ rated torque, at rated speed)								
	Voltage	Less than ±1% (supply voltage ±10%, at rated speed with no load)								
	Temperature	Less than ±1% (0 to +40°C (+32 to +104°F), at rated speed with no load)								

※ For permissible load inertia in the geared motor, refer to 9 page.

※ Enter the ratio in the box(□) model number.

※ The values for each item is for the motor only.

COMMONALITIES

Category	Specifications
SLOW RUN / SLOW STOP	0.5 to 15 seconds (Applicable for both Slow Run and Slow Stop)
Speed Control	1. Built-in Potentiometer 2. External Potentiometer (20KΩ 1/4W)
Input Signal	Photocoupler input method, input resistance: 3KΩ, operates at DC 24V±10%, common for EXT., CW, and CCW
Output Signal	Opencollector output, external use conditions: Less than 26.4V 10mA, common for Speed Out and Alarm Out.
Protection Feature	<p>If following protection functions are operated, control unit alarm signal is output and motor come to stop.</p> <ul style="list-style-type: none"> ● Overload protection : If load exceeds a rated torque in the motor, is approved over approximately 5 seconds. ● Overvoltage protection : If voltage approved in control unit, exceeds top limit in the rated voltage allowable range. ● Under voltage protection: If voltage approved in control unit, less than rated voltage allowable range. ● Icing protection : If sensor wire of cable is shorted during operating the motor. ● Overspeed protection : If motor RPM exceeds 2800 r/min.
Motor Insulation Level	Class B (130°C)
Time Rating	Continuous

GENERAL SPECIFICATIONS

Item	Motor	Control Unit
Dielectric Strength	If applying 60Hz, 1,500V between the coil and the case for 1 minute after continuous operating under normal temperature and humidity conditions, any fault is not occurred.	If applying 60Hz, 1,500V between protection ground terminal and power input for 1 minute, any fault is not occurred.
Insulation Resistance	After continuous operating under normal temperature and humidity conditions, if measured the resistance value between the coil and the case using DC500V Mega Tester, should be over 100M Ω .	If the resistance value between protection ground terminal and power input is measured using DC500V Mega Tester, should be over 100M Ω .
Ambient Temperature	0°C to +40°C(+32°F to +104°F) (nonfreezing)	0°C to +40°C(+32°F to +104°F) (nonfreezing)
Ambient Humidity	Less than 85% (non condensing)	
Atmosphere	No corrosive gas or dust.	
Degree of Protection	IP65 (excluding the output shaft side)	IP10

Caution Use it, ensuring that surface temperature of motor does not exceed over 90°C.

PERMISSIBLE LOAD INERTIA (J)-GEARED MOTOR

$J \times 10^{-4}$ kgf-m²(oz · in²)

Model	Gear Ratio	5	10	15	20	30	50	100	200
XWA610()-□K		1.55 (8.5)	6.2 (33.9)	14 (76.5)	24.8 (135.6)	55.8 (305.1)	155 (847.5)	155 (847.5)	155 (847.5)
XWA825()-□K		5.5 (30.1)	22 (120.3)	49.5 (270.6)	88 (481.1)	198 (1083)	550 (3007)	550 (3007)	550 (3007)
XWA940()-□K		10 (54.7)	39 (213.2)	90 (492.1)	130 (710.8)	360 (1968)	1000 (5467)	1000 (5467)	1000 (5467)
XWA990()-□K		25 (136.7)	100 (546.7)	225 (1230)	400 (2187)	900 (4921)	2500 (13669)	2500 (13669)	2500 (13669)

- ※ □ indicates deceleration ratio.
- ※ () indicates voltage specification.

PERMISSIBLE TORQUE-GEARED MOTOR

N·m / [kgf·cm(lb·in)]

Item	Speed Control Range [r/min] Gear Ratio	20~400	10~200	6.7~133	5~100	3.3~67	2~40	1~20	0.5~10
		5	10	15	20	30	50	100	200
XWA610()-□K		0.22	0.45	0.68	0.90	1.3	2.1	4.2	6.0
		2.2(1.91)	4.5(3.91)	6.8(5.90)	9.0(7.81)	13(11.28)	21(18.23)	42(36.45)	60.0(52.08)
XWA825()-□K		0.56	1.12	1.68	2.20	3.2	5.3	10.6	16.0
		5.6(4.86)	11.2(9.72)	16.8(14.58)	22.0(19.09)	32(27.77)	53(46.00)	106(92.00)	160(138.87)
XWA940()-□K		0.90	1.80	2.70	3.60	5.1	8.5	17.0	30.0
		9.0(7.81)	18.0(15.62)	27.0(23.43)	36.0(31.25)	51(44.27)	85(73.78)	170(147.55)	300(260.38)
XWA990()-□K		2.10	4.10	6.00	8.00	11.5	19.3	30.0	30.0
		20.0(17.36)	40.0(34.72)	60.0(52.08)	80.0(69.44)	115(99.44)	193(167.51)	300(260.38)	300(260.38)

※ □ indicates deceleration ratio.

※ Direction indicated in color □ is the same direction of the motor. The other is reverse direction.

※ () indicates voltage specification.

PERMISSIBLE OVERHANG LOAD AND PERMISSIBLE THRUST LOAD

Model		Deceleration Ratio	Permissible Overhang Load				Permissible Thrust Load	
			10mm(0.3937in) from end of the output shaft.		20mm(0.7874in) from end of the output shaft.		N	kgf(lbs.)
			N	kgf(lbs.)	N	kgf(lbs.)		
Geared Motor	XWA610()-□K	5	100	10(22.03)	150	15(33.04)	40	4(8.81)
		10~20	150	15(33.04)	200	20(44.05)		
		30~200	200	20(44.05)	300	30(66.08)		
	XWA825()-□K	5	200	20(44.05)	250	25(55.07)	100	10(22.03)
		10~20	300	30(66.08)	350	35(77.09)		
		30~200	450	45(99.12)	550	55(121.15)		
	XWA940()-□K	5	300	30(66.08)	400	40(88.11)	150	15(33.04)
		10~20	400	40(88.11)	500	50(110.13)		
		30~200	500	50(110.13)	650	65(143.17)		
	XWA990()-□K	5	300	30(66.08)	400	40(88.11)	150	15(33.04)
		10~20	400	40(88.11)	500	50(110.13)		
		30~200	500	50(110.13)	650	65(143.17)		
Motor	XWM610D		87.2	8.72(19.21)	107	10.7(23.57)	• Do not engage the thrust load. If unavoidable, engage below 50% of motor weight.	
	XWM825D		117	11.7(25.77)	137	13.7(30.17)		
	XWM940D		156	15.6(34.36)	176	17.6(38.77)		
	XWM990D		156	15.6(34.36)	176	17.6(38.77)		

※ □ indicates deceleration ratio.

※ () indicates voltage specification.

GEARED MOTOR

Model : XWA610()-□K

[Unit : mm(inch)]

- Motor : XWM610G
- Gear Head : XTG65K~XTG6200K
- Control Unit : XWD10()

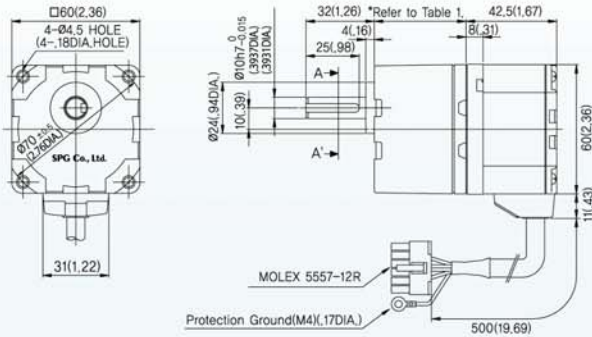

- indicates deceleration ratio.
- ※ Gear head motor is enclosed with a bolt set (refer to P14 for specifications).
- () indicates voltage specification.

Key(accessories)

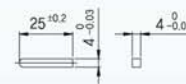

Key Groove

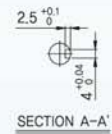

※ Table 1

Gear Ratio	Size:mm(inch)
XTG65K~XTG620K	34(1.34)
XTG630K~ XTG6100K	38(1.50)
XTG6200K	43(1.69)

MOTOR

Model : XWM610D

[Unit : mm(inch)]

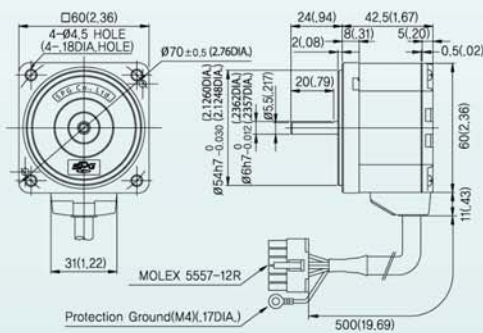

※ Table 2-Weight

Part	Weight:kg.(lbs)	
Motor	0.48(1.06)	
Gear Head	XTG65K~XTG620K	0.28(0.62)
	XTG630K~ XTG6100K	0.33(0.73)
	XTG6200K	0.37(0.82)

GEARED MOTOR

Model : XWA825()-□K

[Unit : mm(inch)]

- Motor : XWM825G
- Gear Head : XTG85K~XTG8200K
- Control Unit : XWD25()

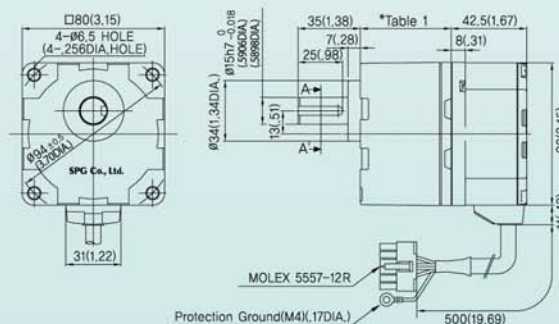

- indicates deceleration ratio.
- ※ Gear head motor is enclosed with a bolt set (refer to P14 for specifications).
- () indicates voltage specification.

Key(accessories)



Key Groove

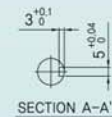

※ Table 1

Gear Ratio	Size:mm(inch)
XTG85K~XTG820K	41(1.61)
XTG830K~ XTG8100K	46(1.81)
XTG8200K	51(2.01)



MOTOR

■ Model : XWM825D

[Unit : mm(inch)]

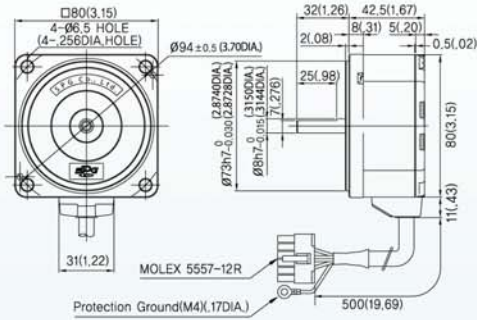

※ Table 2-Weight

Part		Weight:kg.(lbs)
Motor		0.75(1.65)
Gear Head	XTG85K~XTG820K	0.61(1.34)
	XTG830K~ XTG8100K	0.72(1.59)
	XTG8200K	0.80(1.76)

GEARED MOTOR

■ Model : XWA940()-□K

[Unit : mm(inch)]

- Motor : XWM940G
- Gear Head : XTG95K~XTG9200K
- Control Unit : XWD40()

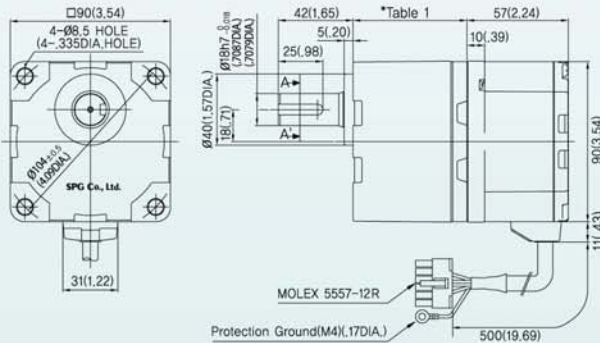

■ Key(accessories)

■ Key Groove

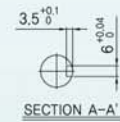
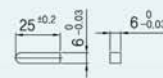

※ Table 1

Gear Ratio	Size:mm(inch)
XTG95K~XTG920K	45(1.77)
XTG930K~ XTG9100K	58(2.28)
XTG9200K	64(2.52)

- indicates deceleration ratio.
- ※ Gear head motor is enclosed with a bolt set (refer to P14 for specifications).
- () indicates voltage specification.

MOTOR

■ Model : XWM940D

[Unit : mm(inch)]

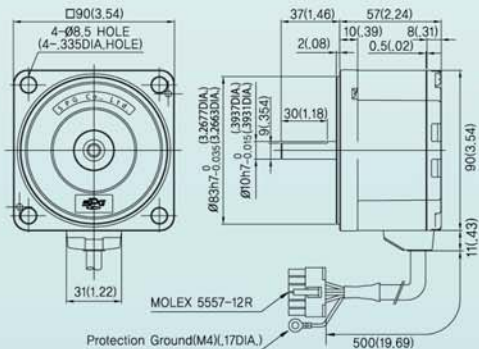

※ Table 2-Weight

Part		Weight:kg.(lbs)
Motor		1.34(2.95)
Gear Head	XTG95K~XTG920K	0.85(1.87)
	XTG930K~ XTG9100K	1.15(2.54)
	XTG9200K	1.30(2.87)

GEARED MOTOR

Model : XWA990()-□K

[Unit : mm(inch)]

- Motor : XWM990G
- Gear Head : XTG95K~XTG9200K
- Control Unit : XWD90()

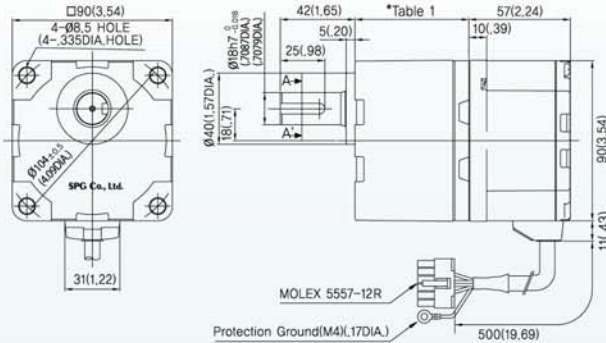

- indicates deceleration ratio.
- ※ Gear head motor is enclosed with a bolt set (refer to P14 for specifications).
- ※ () indicates voltage specification.

Key(accessories)

Key Groove

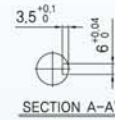
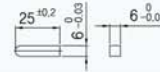

※ Table 1

Gear Ratio	Size:mm(inch)
XTG95K~XTG920K	45(1.77)
XTG930K~ XTG9100K	58(2.28)
XTG9200K	64(2.52)

MOTOR

Model : XWM990D

[Unit : mm(inch)]

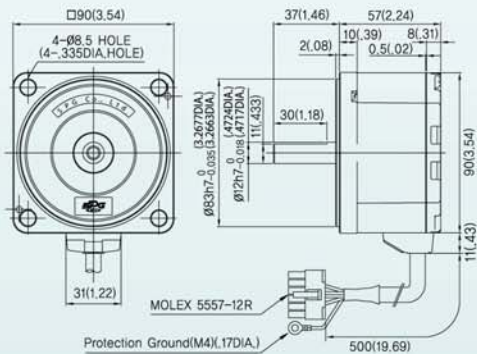

※ Table 2-Weight

Part	Weight:kg.(lbs)	
Motor	1.34(2.95)	
Gear Head	XTG95K~XTG920K	0.85(1.87)
	XTG930K~ XTG9100K	1.15(2.54)
	XTG9200K	1.30(2.87)

CONTROL UNIT

Model(Applicable to all models) : XWD10(), XWD25(), XWD40(), XWD90() (Weight : 0.4kg)

[Unit : mm(inch)]

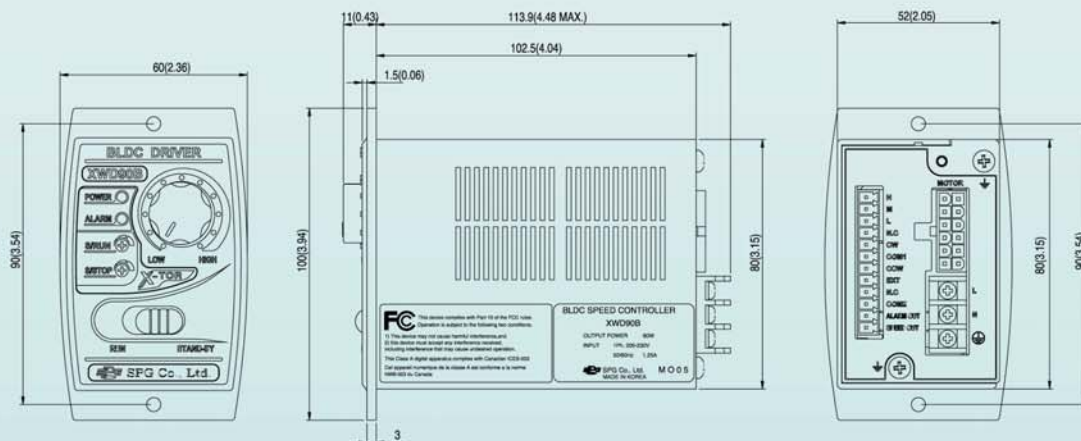

- ※ () indicates voltage specification.

CONTROL UNIT POWER SUPPLY CABLE

■ Applicable to all models (accessories)

[Unit : mm(inch)]

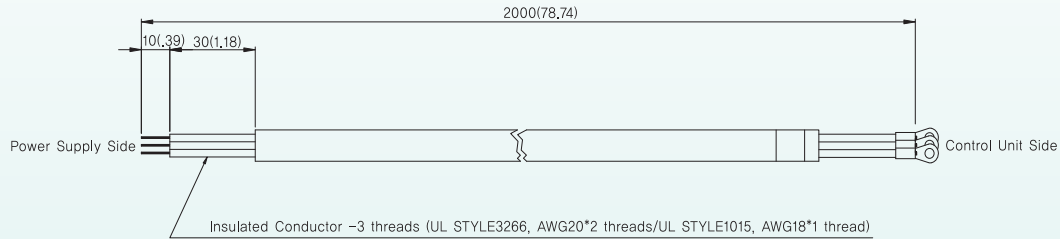

ASSEMBLY BOLT MEASUREMENTS

■ Assembled bolt is attached to gear head or geared motor.

[Unit : mm(inch)]

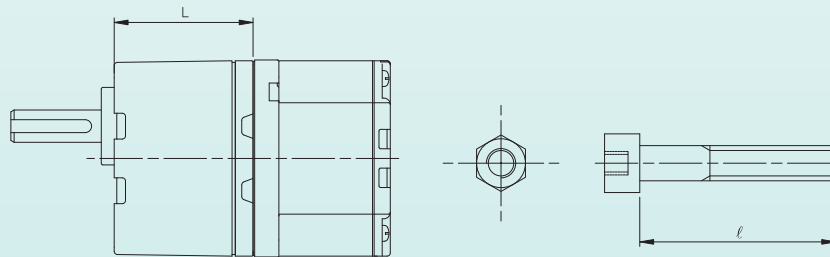

Model		Accessory Bolts (Flat W/S, Spring W/S, hexagonal nut X 4)		
Gear Head	Geared Motor	L (mm)	φ (mm)	Bolt Names
XTG65K~XTG620K	XWA610()-5K~XWA610()-20K	34	50	M4 P0.7
XTG630K~ XTG6100K	XWA610()-30K~XWA610()-100K	38	55	
XTG6200K	XWA610()-200K	43	60	
XTG85K~XTG820K	XWA825()-5K~XWA825()-20K	41	65	M6 P1.0
XTG830K~XTG8100K	XWA825()-30K~XWA825()-100K	46	70	
XTG8200K	XWA825()-200K	51	75	
XTG95K~XTG920K	XWA940()-5K~XWA940()-20K	45	75	M8 P1.25
	XWA990()-5K~XWA990()-20K			
XTG930K~XTG9100K	XWA940()-30K~XWA940()-100K	58	90	
	XWA990()-30K~XWA990()-100K			
XTG9200K	XWA940()-200K	64	95	
	XWA990()-200K			

※ () indicates voltage specification.

XWU610G()/XWU610D()

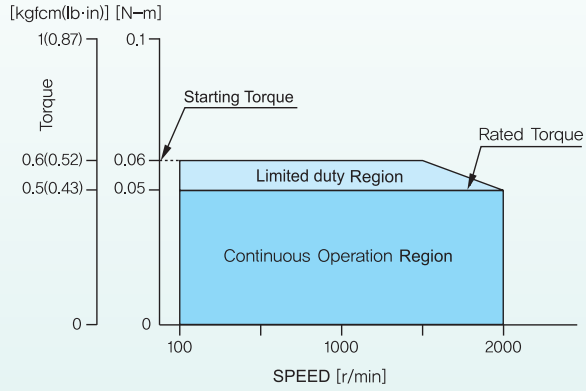

XWU825G()/XWU825D()

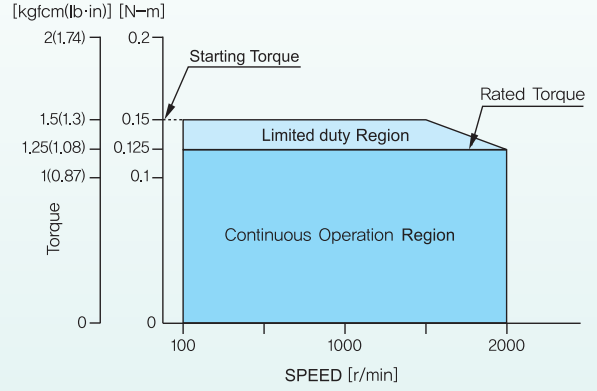

XWU940G()/XWU940D()

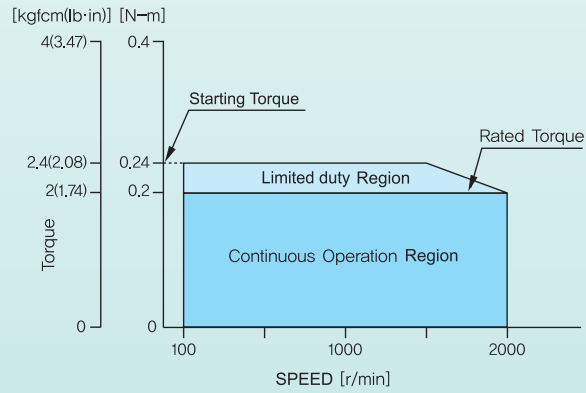

XWU990G/XWU990D()

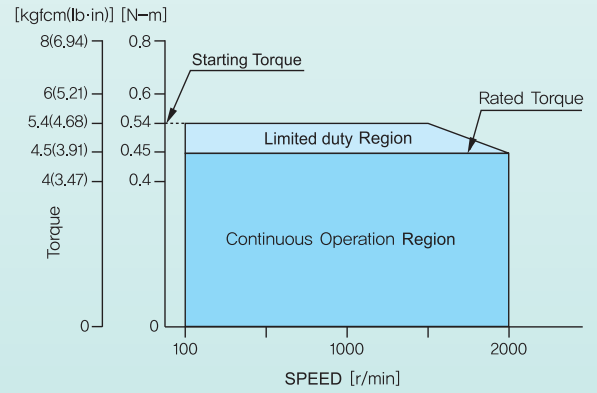

* () indicates voltage specification.

CONTROL UNIT STRUCTURE & FUNCTIONS

Power LED (Green)

Illuminate when power switches on.

Alarm LED (Red)

Illuminate when protection function is operated.

Slow Run Time Dial *

Speed increases slowly when motor operates. Time can be set within 0.5~15 seconds(2000 r/min, during no load) range.

Slow Stop Time Dial *

The motor comes to a gradual stop. Time can be set to within 0.5 to 15 seconds (2000 RPM, zero load).



<Control Unit, Front>

Speed Potentiometer

Rotate the speed dial clockwise to increase the motor's RPM. Speed can be set within 100~2000 r/min range. Upon delivery, it had been set to 0 r/min.

Run / Stand-by Switch

If Run side is selected, motor operates, and if Stand-by mode is turned, motor stops. Upon delivery, it had been set to stand-by mode.

* Slow Run/Slow Stop Time Dial
Rotate clockwise to extend the time. Use a precise, insulated phillips head driver to set. Upon delivery, it had bee set to minimum time.

I/O signal terminal

(Use a twisted pair or shielded wire for connecting).



<Control Unit, Rear>

Ground Terminal

(Use the grounding wire of motor's connector to ground.)

Motor Terminal

Power Terminal

Ground Terminal

* Caution
• Run/Stand-by switch is not ON/OFF switch for power.
• Switch off the power of control unit when motor is stopped for a long time.

INTERFACE DIAGRAM

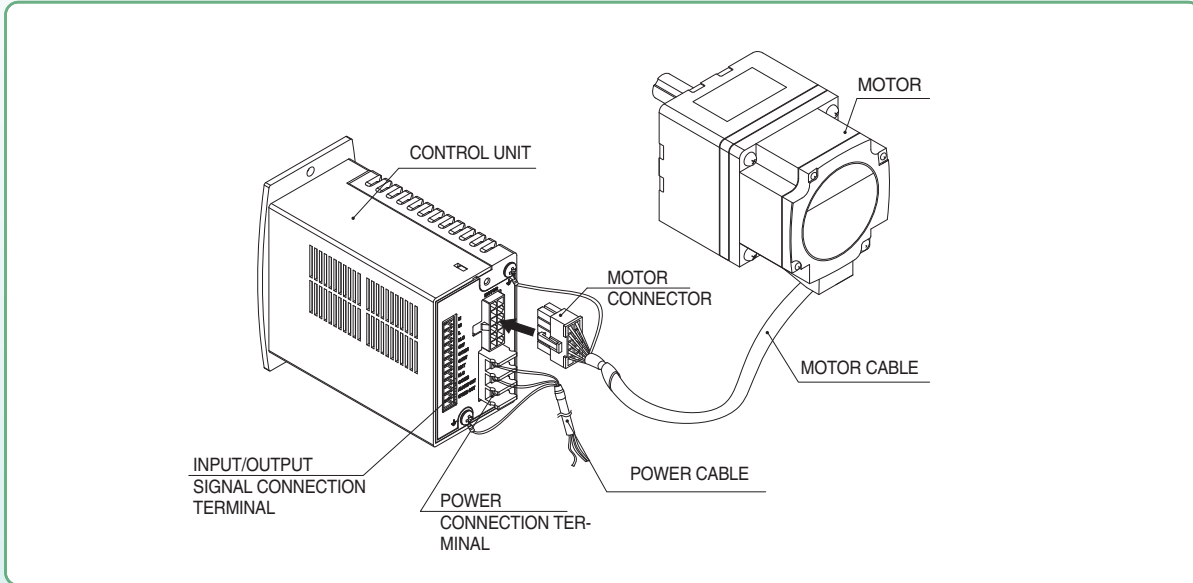

Motor Interface

- Connect motor cable's connector to the connector for connecting the motor of control unit.
- If the motor and the control unit are extended, extension cable(purchase separately) can be extended up to 10,5 m (413.39in).

Caution • Do not machine or modify the motor cable, extension cable. If another product is installed, may result in person's injury and fire.
 • Do not remove cable coating or ground/touch the shield wire. May result in electrical shock.

Power Supply

- Connect the power cable to the power terminal of control unit.
- Power Connection Terminal's Size of Terminal Screw and Cable Size In case of connecting the power connection terminal, use a circular compressed terminal that is insulated and adhesive.

Applied Pressure Terminal

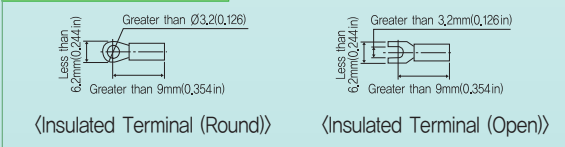

- The size of a terminal screw : M3
- Fastening torque : 0.8 ~ 1 Nm(113~142 oz.in)
- The size of a cable available for connection: AWG16~18 (1.25~0.75 mm²)

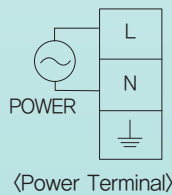

Grounding

- Use a AWG 18 or higher cable to ground.

Wiring the Signal I/O Terminal

- Signal I/O Terminal

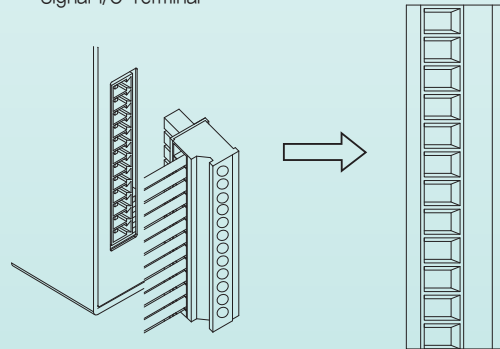

Name	Function
H	Input terminal for external speed setting
M	
L	
NC	No Connection
CW	CW signal input terminal
CCW	CCW signal input terminal
EXT	Input terminal for internal/external speed adjuster selection
COM1/COM2	Common GND for input/output signals
Alarm Out	ALARM signal output terminal
Speed Out	SPEED signal output terminal

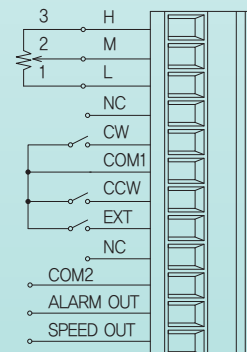

OPERATION

Selecting operation speed

The speed of the motor can be controlled by the internal speed controller within the control unit. It can also be controlled through the attached external speed controller or external direct current voltage. Speed selection ranges are 100~2000r/min. The speed selection can be controlled two ways by using the mixture of internal speed controller/external speed controller and internal speed controller/external direct current voltage(refer to P23).

EX) Selecting by internal speed controller.

Winding it clock-wise will operate the motor faster. (Factory setting : 0 r/min)

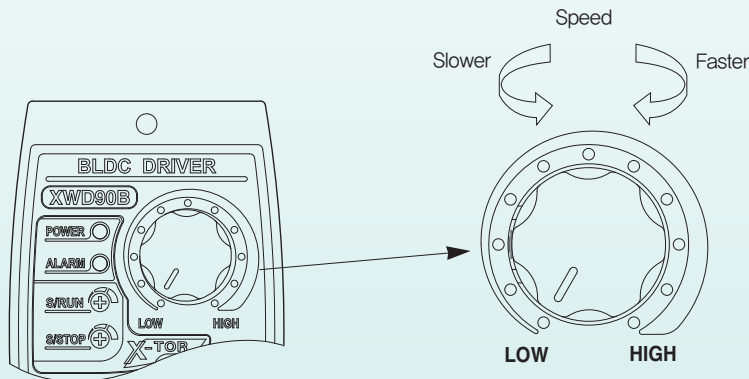

SIGNAL INPUT CIRCUIT

(1) Input Circuit

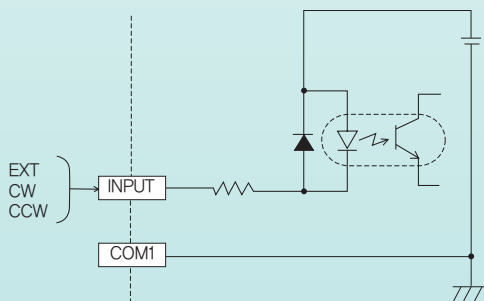

(2) Input Circuit Connection

This connection is used for EXT, CW, CCW

<Non-contact control>

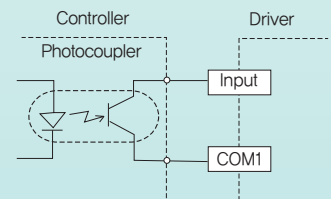
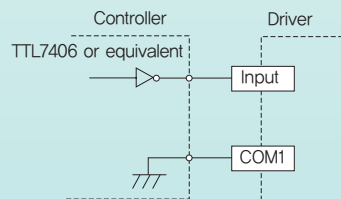

<Contact control>

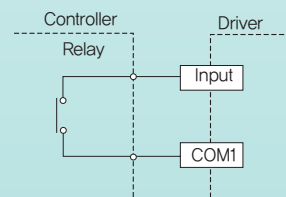

Do not use a solid state relay.(SSR) to turn on or off power. The motor control unit may be damaged if it is used. When you want to use the controller with a built-in clamp diode, pay attention to the sequence of turning on or off the power.

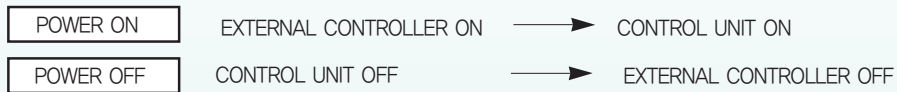

If the control unit power is turned on first when connected as shown on the right, or the controller power is turned off with the control unit power turned on, current will be applied, as indicated by arrow mark of the diagram, and this may cause the motor to be driven. When the power is turned on or off simultaneously, the motor may be driven temporarily due to differences in power capacity. The controller power must be turned on first, and control unit power must be turned off first.

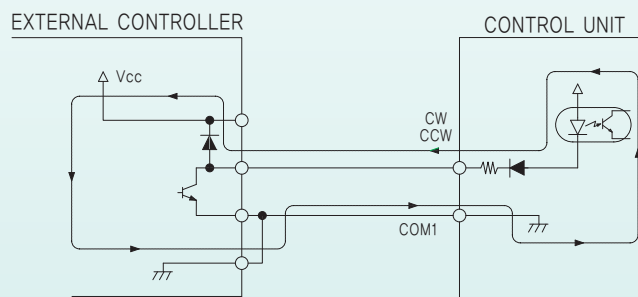

H/M/L

It is a terminal connected for external speed controller and external direct current voltage. Please refer to page 23.

CW input

When CW input is <on>, it accelerates and operates in direction of the CW in accordance to time set up by the slow run time controller. When CW input is <off>, it automatically slows downs.

CCW input

When CCW input is <on>, it accelerates and operates towards the CCW in accordance to time set up by the slow run time controller. When CCW input is <off>, it automatically slows downs.

[Important]

- When CW input and CCW input get turned <on> at the same time CW has priority
 - Immediate seize operation is impossible
 - Please have 20msec of time in between CW and CCW input

EXT input

In <off>(H level) mode, choose internal speed controller. In <on>(L level), choose external speed controller or external direct current voltage.

SIGNAL OUTPUT CIRCUIT

The signal status does not show the voltage level but its photocoupler's (on : electricity flows), (off : electricity does not flow) status

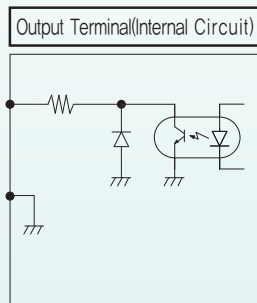

Alarm Out

In the following condition, the protection guard of the control unit comes on, alarm out function turns (On) (L level), and the motor gets turned off.

※ It is shown by the LED's on/flashing sign. Make sure to be informed of the protection guard function.

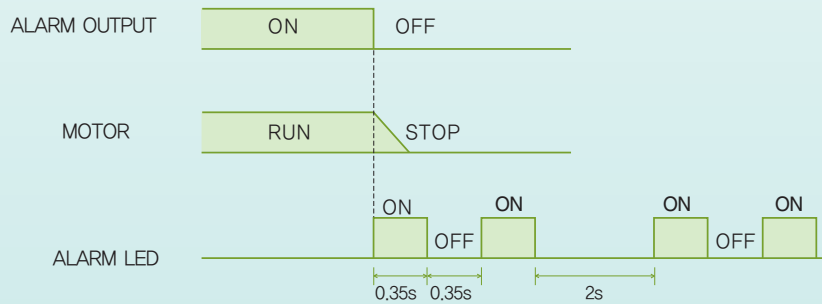

Type of protection function	Alarm LED ON/OFF Cycle	Action
Overload protection	1 Cycle	Activated when a load exceeding the rated torque (load torque or motor current of 130% max. of rated load or rated motor current) is applied to the motor for 5 seconds or more or when the motor is operated in short cycles of stopping/starting or CW/CCW rotation.
Open-Phase protection	3 Cycle	Prevents motor malfunction when the sensor cable within the motor cable is disconnected during motor operation. (An alarm signal will not be output while the motor is at a standstill.)
Under voltage protection	4 Cycle	Activated when a input voltage to the driver is less than specified voltage.
Overspeed Protection	6 Cycle	Activated when the speed of the motor exceed 2800r/min or when it shows abnormal speed.
Overvoltage protection	ON	Protects the driver against damage when the motor is driving an inertial load exceeding the permissible inertial load, or when the motor shaft is turned by the load (during lowering operation).

When connected as above, alarm out gets (off)(H level) if the control unit is normal, and (on)(L level) when it alarms. When the alarm out is (on), stop the operation of the motor and shut down the control unit. When the motor cable is normal, re-check the usage conditions (overload torque, operation patterns, voltage)

Speed out

In accordance to the motor operation, it outputs 12/15 pulse per cycle(of the motor's output shaft). Thus it is possible to calculate the cycling speed of the motor by measuring the output frequency of the speed out.

$$\text{Speed out output frequency(Hz)} = \frac{1}{T}$$

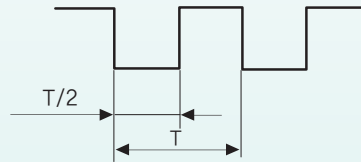

With 10W/40W/90W

$$\text{Cycling speed of the motor(r/min)} = \frac{\text{Output frequency of the Speed Out(Hz)}}{12} \times 60$$

With 25W

$$\text{Cycling speed of the motor(r/min)} = \frac{\text{Output frequency of the Speed Out(Hz)}}{15} \times 60$$

If you need the cycling speed of the motor's cycling head or that of reduction gear, Digital Speed Indicator(SID 250) is available.(Sold separately)

[Important]

- To extend the input/output cables, please do so under 2m.
- Input/output cables should be wired separately from power cables and motor cables.

SLOW RUN / SLOW STOP TIME SETTING

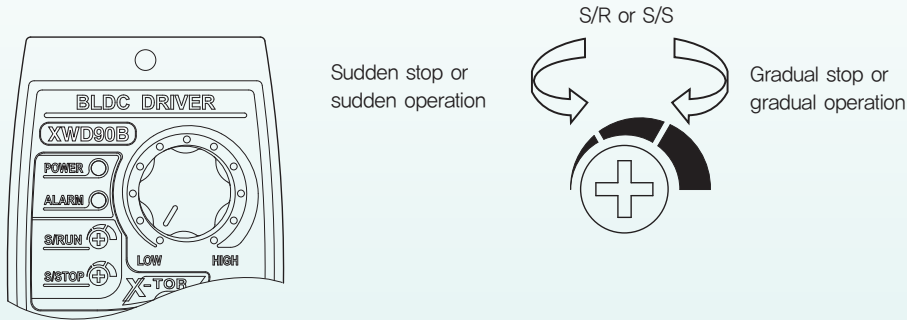

Slow Run Time Setting Potentiometer

The length of time between the start of the engine to the reach of desired speed is controlled by the "Slow Run Time Controller". When it is wound clock-wise, the time expands. The range of selection is in between 0.5sec ~ 15sec.

Slow Stop Time Setting Potentiometer

The length of time between the regular operation of the engine to a full stop of the engine is controlled by the "Slow Stop Time Controller". When it is wound clock-wise, the time expands. The range of selection is in between 0.5sec ~ 15sec.

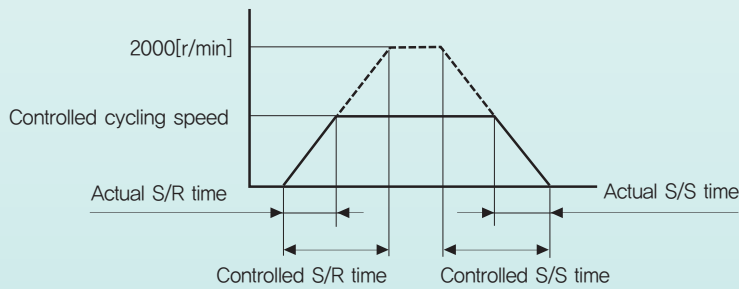

[Important]

- To change the cycling direction of the motor, slow down the motor with "Slow Stop Time Controller" and start the motor with "Slow Run Time Controller".

SPEED SETTING

For internal speed adjuster

- Speed is set with speed adjuster on the front panel of control unit.
When EXT. input is off, internal speed adjuster will be selected.

Connecting External Speed Adjuster

When connecting an external speed adjuster, use the enclosed external speed adjuster and the signal wire exclusively designed for the external speed adjuster.

1. Among signal wires for the external speed adjuster (referred as signal wire from now on), connect the lead wire to the terminal 3 of the external speed adjuster and H input terminal.
2. Connect the lead wire of the signal wire to the terminal 2 of the external speed adjuster and M input terminal.
3. Connect the lead wire of the signal wire to the terminal 1 of the external speed adjuster and L input terminal.
4. Connect the shield wire of the signal wire to the terminal of COM1.
(Make sure that the shield wire of the external speed adjuster does not touch other terminals.)

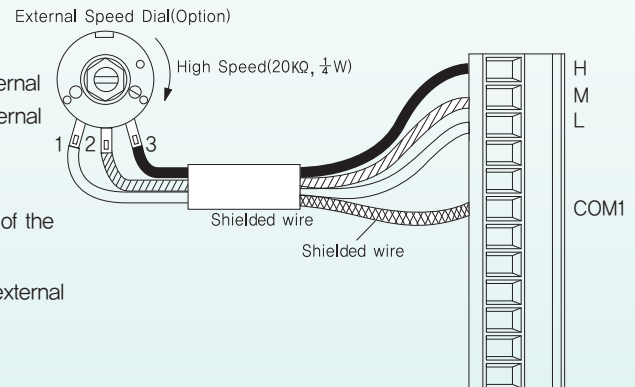

INSTALLATION

- Install the control unit on a flat, metal panel that has strong endurance to vibration.
- When installation hole of control unit is used, tighten it with M4 screw and nut.
- When control unit is installed, install it with one of the two vents is facing downward.
- Install it with separating the control unit from the installation box over 25 mm in the horizontal, over 50 mm in the vertical.

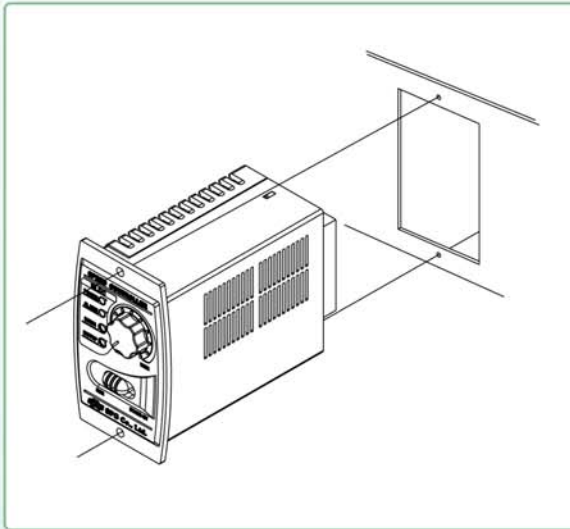

Control Unit Panel Process Criterion

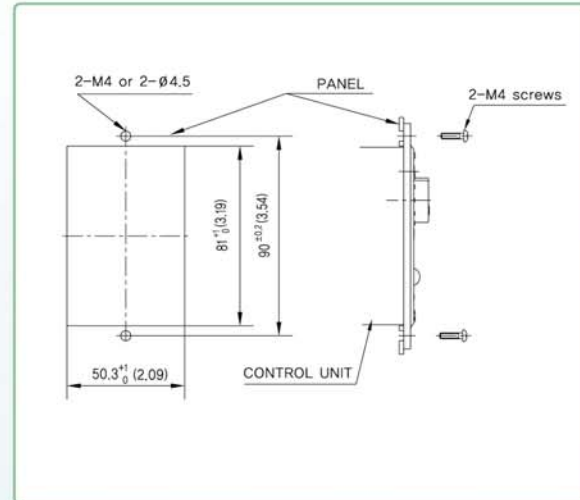

Caution

- Tightening torque for screw must be below 10kgf · cm (8.68 lb·in). If torque exceeding 10kgf · cm(8.68 lb·in) is applied, may result in damage to the control unit.